

Unleashing the Power of DCC



Digital

plus
by Lenz®

LZV100 Command/Power Station Operations Manual

Version 3.4

December 2002

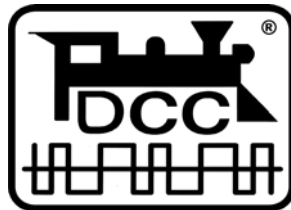

Submitted to the NMRA for
formal C&I testing.
Warrant pending

Welcome!

We would like to congratulate you on your acquisition of the **Digital plus by Lenz**[®] system and we hope you will enjoy working with this model-railway control system. Thank you for being our new customer!

The purpose of this operating manual is to explain the use of the system and its components. In order to proceed as quickly as possible to the pleasure of operating your model railway with DCC, begin by reading the section "First Steps". After you have operated your first train you will be better able to follow the step by step description of your system's entire range of functions. It is not necessary to understand or use all the system's features. Select the set of features you are comfortable with and enjoy your model railroad.

If you still have questions after reading this operating manual, for which you can not find the answers, please contact us. We will be happy to help. There are four different ways of contacting Lenz Elektronik GmbH:

	Europe	North America
Postal address:	Lenz Elektronik GmbH Huettenbergstrasse 29 D-35398 Giessen	Lenz Agency PO Box 143 Chelmsford, MA 01824
Phone	++49 (0) 6403 900 133	++1 978 250 1494
Fax	++49 (0) 6403 900 155	++1 978 455 LENZ
Email	info@digital-plus.de	support@lenz.com

Do you have everything?

Please check, to ensure that all the components of the LZV100 have been delivered:

- LZV100 – Command Station/Power Station (Booster)
 - one 5-terminal, one 4 terminal and one 3-terminal green connector attached to the rear of the LZV100
 - one 4-terminal black connector attached to the rear of the LZV100
 - operating manual (this booklet)

If an item is missing, please contact your retailer to have the missing item replaced.

In order to use the LZV100 you will also need an XpressNet handheld and a suitable transformer for powering the LZV100.

1 **Important information — Please read first!**

Your **LZV100** command/power station is the central component of your **Digital plus by Lenz**[®] system and was submitted to intensive testing before delivery. Lenz Elektronik GmbH guarantees fault-free operation if you follow the advice given below:

☞ *Do not connect the **LZV100** to any device not addressed in this manual. Even if other devices use the same connectors, you must not operate the **LZV100** with those devices. The fact that the connectors are similar does not automatically mean that you may use them for operation, even if you are dealing with other model railroad control systems.*

Do not expose the **LZV100** to moisture or direct sunlight.

1.1 **Notations and symbols:**

Cross references:

(⇒p. 23)

This arrow points you to a particular page in this operation manual, where you will find additional information about the subject at hand.

Important notes:

☞ Text marked with this symbol and frame contains especially important information and tips.

☞ **If you have problems,**
please first check this operation manual to see if you may have missed a direction for use. The table of contents and especially the section “Troubleshooting” will help.

2 Contents

1 Important information — Please read first!	3
1.1 Notations and symbols:	3
2 Contents	4
3 Quick Start Users Guide	5
3.1 Connection and initial operation	5
4 System architecture of your DIGITAL plus system	7
4.1 LZV100 Command Station	9
5 Installing the LZV100	11
5.1 Power Plug (UVJKL)	11
5.2 Power Station Interface Plug (CDE)	12
5.3 Programming Track Feedback bus Plug (PQRS)	12
5.4 XpressNet plug (LMAB)	13
5.5 XpressNet 5-pin Din Connection	13
6 Configuring the LZV100	14
6.1 System Reset	14
6.2 Auto mode/Manual Mode	14
6.3 Configuring the LZV100 power station	15
7 Operation considerations	17
7.1 Achieving the maximum LZV100 DCC track power	17
7.2 The LZV100 locomotive database	19
8 Expanding Your Digital plus DCC system	20
8.1 Adding XpressNet to allow additional input devices	20
8.2 More power through more power stations	21
8.3 Adding a Layout Feedback Bus	23
8.4 Using RailCom	23
9 Installing XpressNet	24
9.1 Using 5 pin Din Plugs	24
9.2 Using Modular Plugs	25
9.3 Using the LA152	26
9.4 XpressNet Wiring	27
10 Layout Wiring considerations	28
10.1 What is a Common?	28
10.2 Common Rail Wiring	29
10.3 Two rail wiring (Direct Home Wiring)	29
10.4 Common transformer	29
10.5 Mixing Digital and Analog Operations	29
10.6 Connecting a reverse loop	30
11 Connecting the LZV100 to Other Manufacturer's Power Stations (Boosters)	32
12 Troubleshooting the LZV100	33
13 Radio And Television Interference	35
14 North American Warranty	36

3 Quick Start Users Guide

In this section you will learn about:

- the few steps that you need to know to operate your *Digital plus by Lenz NMRA DCC* model railroad control system.
- how to operate your first train.

In the later sections, the whole range of functions of the LZV100 will be explained in detail.

3.1 Connection and initial operation

1. Plug the 5 pin din plug at the end of the LH100 or LH90 cord into the 5 pin din socket that is located on the rear of the LZV100

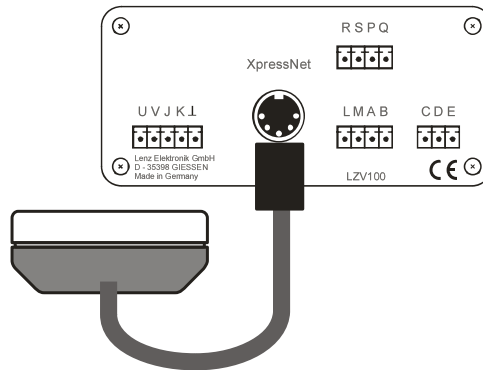

2. Connect terminals **J** and **K** of the LZV100 power station to the tracks of your model railway. You can pull off the green terminal connectors on the back of the LZV100. This will facilitate the installation of cables. Make sure that no other transformers or operating controllers are connected to the tracks.

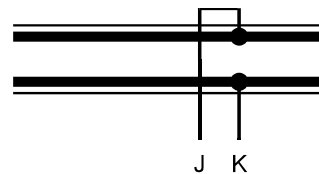

3. For a quick start, connect terminals **U** and **V** of the LZV100 to any model railway transformer with a 14-18 VAC voltage. For initial operation virtually any transformer with a current rating of greater than 1 amp will work. To operate the maximum number of locomotives a transformer with a minimum capacity of 6 to 8 Amp transformer should be used for the LZV100. See (⇒p. 17) for more details on suitable transformers.

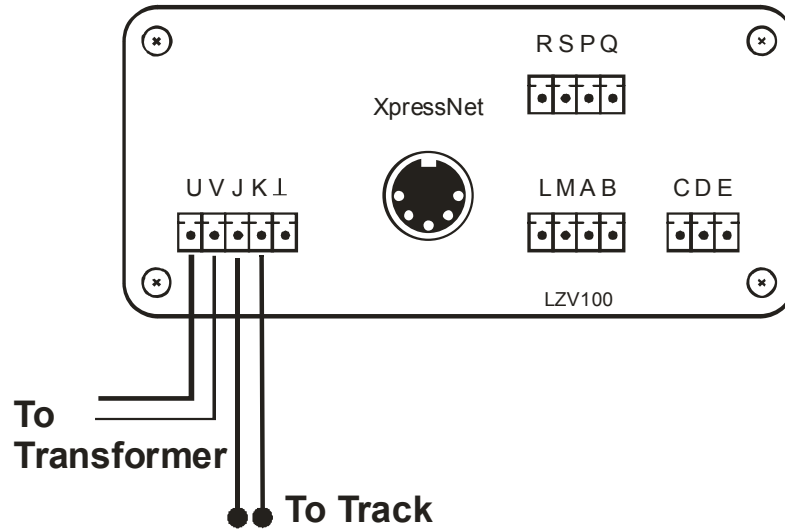

- Put the locomotive which is equipped with the locomotive decoder onto the track. (refer to the instructions that came with the decoder for installation instructions)
- Plug the power cord of the transformer into a wall socket. The display on your LH100 or LH90 lights up and the red led's on the LZV100 turns on solid red.

**You can now start operating trains!
(Yes, already!)**

☞ Refer to the “Operating your first train” in the front of your handheld manual for complete instructions on how to use your new handheld to operate your first train.

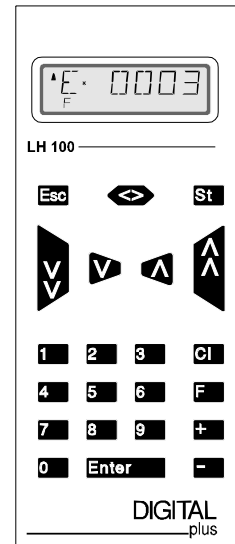

4 System architecture of your DIGITAL plus system

The LZV100 is the central hub in your NMRA DCC DIGITAL plus system. DIGITAL plus is a digital multi-train control system for all model railroad scales developed in close cooperation with model railroaders worldwide. Figure 1 shows the simple and clear system design of DIGITAL plus.

DIGITAL plus is compatible with NMRA-DCC systems and their locomotive and accessory decoders. It is also compatible with all **XpressNet** certified handhelds or other system devices. If you have an older NMRA DCC system, you can use this older system as a handheld using the Translation Module LC100.

The capabilities of DIGITAL plus are to a large extent determined by a program running inside the unit, the software. Version 3 is our 4th major system release.

 **The advantage of this approach is that new functions can be adopted simply by changing the software. It is not necessary to purchase new units. This way it is easier to implement suggestions for improvements from model railroaders.**

Digital plus is designed with a non-proprietary open architecture. Each device in this distributed architecture contains the intelligence necessary to provide support to the external device it is supporting. This distributed architecture provides exceptional performance and allows us to add new capabilities without impacting existing devices.

- **XpressNet Communication Network**

The heart of the Digital plus communication architecture is the high speed state of the art network called **XpressNet**. **XpressNet** is a distributed multi-tier network based on the worldwide RS485 standard. Each device on **XpressNet** contains a dedicated microprocessor that is responsible for providing its own unique user interface capabilities. This allows any certified **XpressNet** device manufactured by any one of a number of manufacturers to be used with your Digital plus system.

XpressNet provides the peer to peer data exchange between each input device and from each input device to the DCC signal generator contained in the command station. The **XpressNet** network consists of a 4 wire twisted pair connection. **XpressNet**

may be up to 1000m (3300 feet) long and can support up to 31 simultaneous input devices. **XpressNet** is the highest performance communication network in the DCC industry, providing the modeler with exceptional growth possibilities.

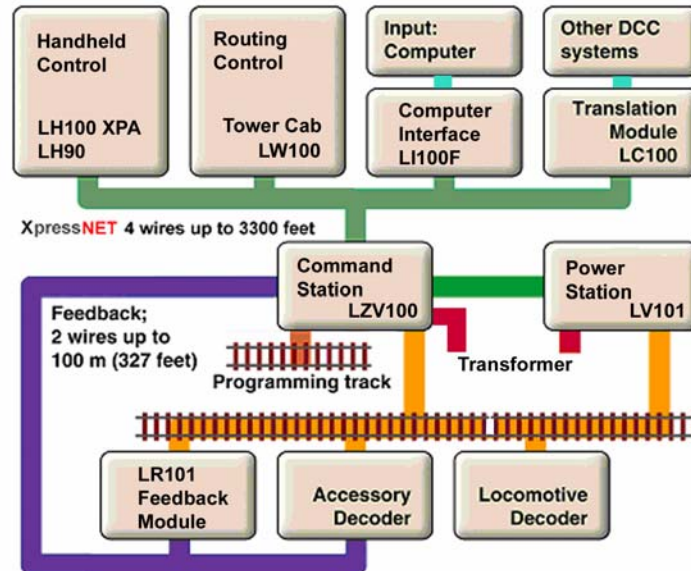

Figure 1: Digital plus system overview

- **Power Station Interface bus**

A two or optional three wire bus connects the command station to as many power stations (boosters) that are needed to power the layout. The LZV100 and all Digital plus power stations are designed to follow the proposed NMRA Power Station Interface RP. All Digital plus power stations are optically isolated to allow safe connection to all forms of layout wiring including common rail wiring.

- **Feedback bus**

The LZV100 provides the capability for a separate 2 wire feedback bus to provide a connecting link between command station and feedback capable modules. A separate bus was chosen to provide maximum performance even in the largest of layouts.

4.1 LZV100 Command Station

The LZV100 has four components built in: a command station, a power station (booster), a RailCom component, and a layout feedback component.

4.1.1 LZV100 Comand Station Component

The core of the LZV100 is its Command Station. The LZV100 coordinates the input devices (Hand Held Controller LH100, etc.) and is also responsible for data processing. Information is exchanged between Command Station and input devices via a 4-wire cable, called **XpressNet**.

4.1.2 LZV100 Power Station (booster) Component

The LZV100 also includes an powerful internal 5 amp power station. The LZV100 power station provides clean and safe DCC power to the track. New circuitry has been developed to reduce noise, which provides exceptionally clean power to operate your DCC equipped trains. Safety features include:

- Both short and overload detection that turns off the power to the track whenever a short or overload condition is detected. This protects both your trains and the LZV100 electronics.
 - Opto-isolation to safely isolate your power station interface wiring from your track wiring. This eliminates any possibility for hidden ground loops through your power station.
 - Fail Safe runaway protection is provided by requiring a 7 volt signal on the DCC Control Bus (the C and D wires). This prevents the LZV100 from accidentally sending out power to the track when the command station stops transmitting packets.
 - The LZV100 has a fault detection LED located on the front of the unit. When the power station is in use, the LED on the front is lit. If the power is on, but no information is being transmitted over the Power Station Interface (connections **C** and **D**), the LED will flash slowly. The LED will also flash quickly when the LZV100 has detected a short or experienced a thermal overload. It will blink slowly when using the PQ, programming outputs and double blink. when the power station itself is being programmed. (⇒p. 15)

4.1.3 LZV100 RailCom Component

RailCom is the next generation of DCC. With RailCom the decoder can communicate back information to the command station and to the handheld device that is controlling it. The LZV100 has a built-in RailCom detector designed to be able to receive the information that the decoder is transmitting. For more precise location detection additional RailCom detectors can be added.

The NMRA DCC Working Group is still defining the transmission protocol. To provide them more time to work this out, we have shipped the LZV100 without this software enabled. In the spring of 2002 this specification should stabilize at which time we will provide a software upgrade to enable this feature.

4.1.4 Layout Feedback Component

The LZV100 also has a dedicated processor for handling layout feedback. This optional feature enables users to install advanced detection and signaling systems.

5 Installing the LZV100

There are five plugs on the rear of your LZV100. Each is used to connect a different feature of your system.

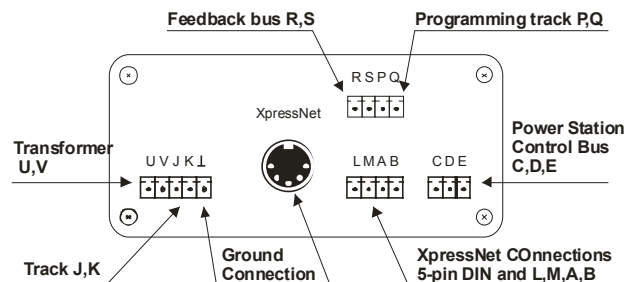

Figure 2: Complete Connections of the LZV100 Command/Power Station

5.1 Power Plug (UVJK⊥)

On the lower left hand side of the LZV100 is a 5 pin green connector used for connecting the LZV100 to the transformer and the track.

The LZV100 command/power station is connected to the AC output of the transformer with 2 wires at terminals **U** and **V** (see Figure 2).

The track is connected to terminals **J** and **K** (see Figure 3). Use only wire of sufficient gauge to connect to the tracks (minimum 18 gauge) and either use parallel wires or twist the wires to reduce radio interference.

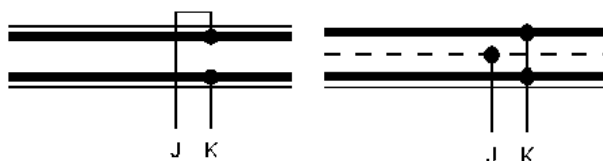

Figure 3: Connecting 2-rail track Connecting 3-rail track

A fifth connection labeled '⊥' on the power plug is the power station ground. This connection can be used in some wiring schemes to form a common between power stations. (⇒p. 28)

5.2 Power Station Interface Plug (CDE)

Terminals **C** and **D** transmit the data signal needed should you ever need additional Power Stations (LV101's, LV200s) to expand your DCC power. If no additional power stations are needed then no further connection is needed using this plug. These terminals are connected with the corresponding terminals on the Power Station with a twisted pair wire (see Figure 2). You can easily make a twisted pair wire from two normal single wires that you twist together.

The terminal **E** connection between to the LZV100 is optional. If terminal **E** on the Command Station is connected to terminal E on the auxiliary Power Station, the Power Station is able to provide feedback about overloads. If an overload occurs and terminal **E** is connected, the Command Station will then turn off all other Power Stations and send the corresponding information to Hand Held Controllers and other input devices. You can also use a pushbutton to connect terminal **E** to connection **M**. This allows the push button to be used as a layout emergency stop.

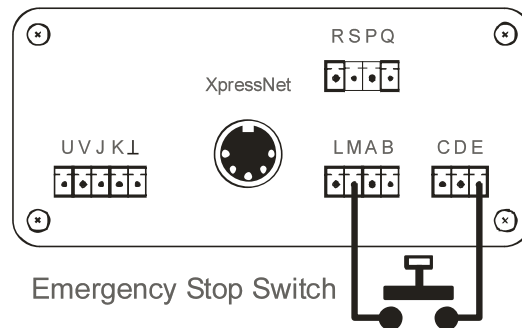

Figure 4: Installing an emergency stop switch

5.3 Programming Track Feedback bus Plug (PQRS)

The LZV100 has a separate outputs for service mode programming. This allows the user to have full read/write capability to any decoder. Connect the programming track to terminals **P** and **Q**. This track must be completely isolated from the rest of the layout.

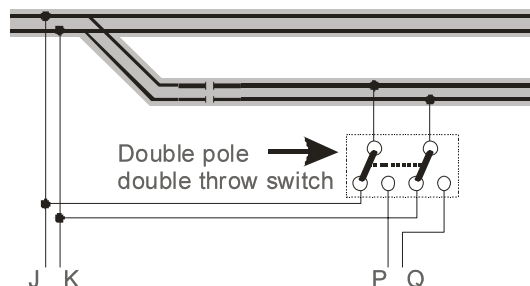

Figure 5: Programming track installation

The **feedback bus** is used for advanced layout control functions. Via these wires, which also must be a twisted pair, the Command Station asks for the state of, for example, turnouts or track occupancy detectors. For this purpose, feedback units are connected to this (Accessory Decoder with Feedback LS100 or Feedback Encoder LR101). For more details on connecting these units, please refer to the respective manuals. If used the feedback bus is connected at terminals **R** and **S**.

5.4 XpressNet plug (LMAB)

The LMAB plug is designed for more permanent XpressNet connections. The wires at terminals **A** and **B**, are used to exchange data, the wires at terminals **L** (plus) and **M** (minus) are used to supply power with the XpressNet devices. For more information on wiring XpressNet see Installing XpressNet (⇒p. 24) later in this manual.

5.5 XpressNet 5-pin Din Connection

This connection allows you to easily plug in one XpressNet device with no further wiring. Should your XpressNet ever develop a wiring problem, you can unplug the LMAB plug and use the Din Connection to check out your system. If desired the entire XpressNet can also plug into this socket.

6 Configuring the LZV100

There are several settings that can be configured on the LZV100. These settings can be activated from any **XpressNet** handheld.

6.1 System Reset

In the rare event that you desire to return the LZV100 to its factory default condition you can perform a LZV100 Reset.

- 1) Set your handheld to operate locomotive 00 (the analog locomotive) and bring that locomotive to a stop
- 2) Press the F4 key 25 times in succession. You may notice that after the 20th time that a brief power interruption occurs on the layout.
- 3) Remove power from the LZV100. When you next power up the system, all memory will be returned to factory default settings.

☞ all memory including knowledge of consists will be removed from the LZV100 memory when you perform a reset operation.

6.2 Auto mode/Manual Mode

The LZ10 has two modes of operation. In manual mode (the default) the LZV100 activates the F0 and F1-F4 functions that were on when the LZV100 was last shut down. In automatic operation the speed and direction of all locomotives are also returned to what they were when the LZV100 was last powered down.

To reconfigure the LZV100 for automatic operation perform the following operation.

- 1) Set your handheld to operate locomotive 00 (the analog locomotive) and bring that locomotive to a stop
- 2) Press the F1 key 6 or more times. When next you power up your LZV100 it will be in automatic mode.

To return the LZV100 to manual operation perform the following operation.

- 1) Set your handheld to operate locomotive 00 (the analog locomotive) and bring that locomotive to a stop
- 2) Press the F2 key 6 or more times. When next you power up your LZV100 it will be in manual mode.

6.3 Configuring the LZV100 power station

The DCC track voltage and several additional power station parameters within the LZV100 can be set using ops mode programming (POM). The sequence is a two step process. The first step is to write a value of 50 to CV7. This activates the programming process. The next value programmed into CV7 (if valid) is used to indicate the new DCC track voltage. The programming process is terminated once a new value is received or if a new value to CV7 is not received within 15 seconds.

The following table lists the LZV100 feature set that can be programmed using this operations mode programming (POM) sequence.

Write to CV	Effect
CV7=50, CV7=90:	E-line to the LZ is activated (default)
CV7=50, CV7=91	E-line to the LZ is deactivated:
CV7=50, CV7=99:	Return to default values

The following table shows the programming sequences used to set the DCC track voltage for the LZV100 using operations mode programming (POM).

Write to CV7:	DCC Track Voltage	Write to CV7:	DCC Track Voltage
CV7=50, CV7=22:	11V	CV7=50, CV7=34:	17V
CV7=50, CV7=23:	11,5V	CV7=50, CV7=35:	17,5V
CV7=50, CV7=24:	12V	CV7=50, CV7=36:	18V
CV7=50, CV7=25:	12,5V	CV7=50, CV7=37:	18,5V
CV7=50, CV7=26:	13V	CV7=50, CV7=38:	19V
CV7=50, CV7=27:	13,5V	CV7=50, CV7=39:	19,5V
CV7=50, CV7=28:	14V	CV7=50, CV7=40:	20V
CV7=50, CV7=29:	14,5V	CV7=50, CV7=41:	20,5V
CV7=50, CV7=30:	15V	CV7=50, CV7=42:	21V
CV7=50, CV7=31:	15,5V	CV7=50, CV7=43:	21,5V
CV7=50, CV7=32:	16V (default)	CV7=50, CV7=44:	22V
CV7=50, CV7=33:	16,5V		

7 Operation considerations

Before use, remove all capacitors (if present) that are connected to the track intended for interference control. A capacitor is only needed for conventional operations to prevent radio interference. In DCC operation a capacitor corrupts the data format and the error free data transfer is disturbed.

It is normal for the LZV100 to get warm during operation. Ensure sufficient airflow around the LZV100 to prevent the internal safety circuits from activating during normal operations.

 **Never allow your layout to operate without supervision!
If there is an unnoticed short, the heat build-up could
present a fire hazard!**

7.1 **Achieving the maximum LZV100 DCC track power**

There are several protection circuits inside the LZV100. These are designed to shut down the track output when a short or overload occurs. If an LZV100 has been shut down due to detecting a short or overload, it will check to see if the overload condition has been corrected and restart after a short delay.

1) The fast acting current limiting circuit is designed to very quickly shut down the LZV100 track output if a short is detected. This circuit activates at over 5 Amps.

2) Thermal overload protection. The LZV100 has a long term thermal overload circuit designed to shut down if its temperature exceeds its rated capacity or value.

How does this translate to the output power you can expect?

For short term loads such as locomotive start up or slow speed operation the LZV100 can deliver over 5 amps of DCC track power.

For long term loads, the LZV100 can continuously deliver 5 Amps at the DCC-voltage you set, as long as the difference between input and output voltage is low enough to prevent the LZV100 from prematurely overheating. Otherwise the thermal overload protection will limit the power output and shut down the LZV100.

That means you can achieve significantly more track current for running trains with a power supply that matches best to the LZV100s potential.

Over temperature is the most common reason that the LZV100 shuts down before a short is detected. To maximize the DCC track output current, you need to have a transformer that puts out a voltage that is close to the DCC track voltage under load because any voltage above the regulated track voltage generates heat. It is normally this heat that limits the output power of the LZV100.

In order to achieve the desired output voltage, you must use a transformer with an output voltage that is as high as the desired track voltage. But do not overdo it: The transformer voltage should be matched as closely as possible to the desired track voltage. Too high of a transformer voltage just generates unnecessary heat loss in the power station, and this will lead to premature triggering of the thermal overload circuit, before the maximum output power is achieved.

7.1.1 Selecting the right transformer for your LZV100

To power your LZV100 you will need a transformer that delivers between 14 and 16V AC under load for H0 and smaller scales. Voltage that exceed this is wasted in excess heat, which reduces the effective capacity of the unit. In order to make it possible for the LZV100 power station to deliver its 5 amp rated capacity and support a full complement of XpressNet devices, the transformer also has to be able to deliver a amperage of at least 6A. You can use a transformer that delivers less current, but then you will not be able to operate as many trains. The transformers voltage must not exceed 18V AC voltage.

The following transformers are recommended for the LZV100:

- Digital plus TR100 (order-no. 26000) (220 volts)
- Digitrax PS515 Power supply (110 volts) (DCC Track voltage lower than 14 volts)
- Lionel Trainmaster PH1 (110 volts)

If you wish to use a different transformer, please note that it should be a model railroad transformer with a 'UL', 'GS' or 'CE' symbol.

7.2 The LZV100 locomotive database

The LZV100 maintains a database of all locomotives operated. The database can contain up to 256 entries. Each time you enter a new locomotive address and provide speed or function information the locomotive is added to the database which is maintained between operating sessions. The database maintains important information about the locomotive such as current state and consist information.

This information is used by XpressNet handhelds to provide the transparent interface and implement features such as “*Smart Consisting*”. If you exceed the 256 locomotive limit the LZV100 will initiate an error message to the handheld. If this occurs you will need to go through the database and remove unneeded locomotives or reset the system. Removing a locomotive from the database will remove all knowledge of the locomotive from the system. To remove locomotives from the LZV100 database see your LH100 or LH90 operators manual.

8 Expanding Your Digital plus DCC system

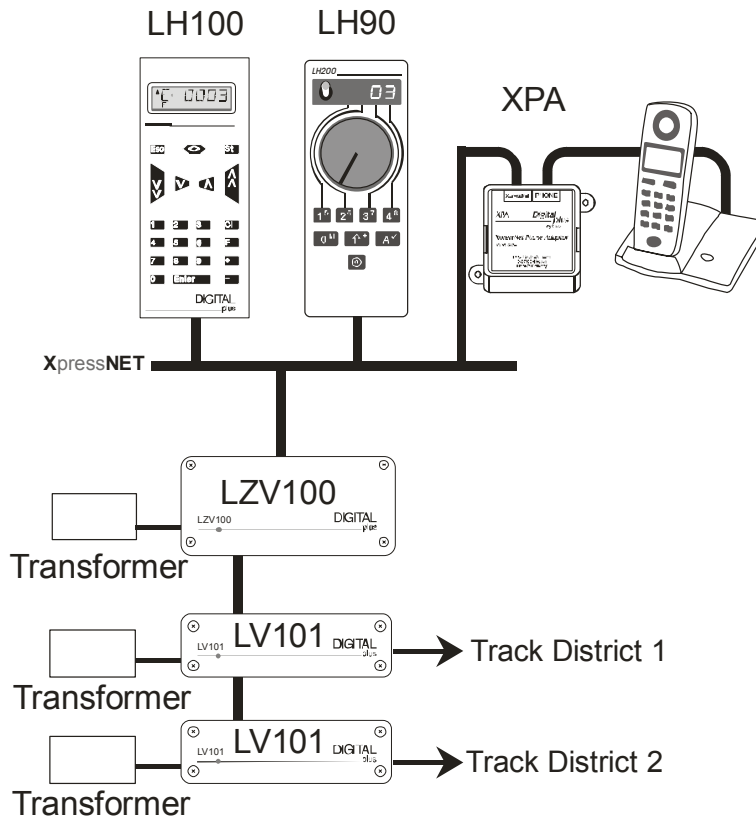

Figure 6: Expanding your system

In this section you will learn:

- how to connect more input devices (handheld controls etc.) to your system through XpressNet
- how you satisfy a larger power requirement for your model railway by installing additional power stations.

8.1 Adding XpressNet to allow additional input devices

Your **Digital plus by Lenz**® SET has the ability to easily expand using its support of XpressNet. XpressNet is a leading model railroad high speed network protocol. It is based on the electronic industry standard RS-485 hardware. The key advantages of this protocol are its expandability and the fact that it is supported by a growing number of Model Railroad manufacturers. For installing

XpressNet refer to "Installing XpressNet" (⇒p. 24).

XpressNet input devices cover a wide variety of options including a variety of handhelds, computer interface and transition modules, that is, all devices from which you control your model railway. The Command Station in the LZV100 not only generates the track format, but also evaluates information from other XpressNet-input devices and converts them into control commands for locomotive decoders and turnout decoders. The XpressNet network is the link between additional input devices and the command station.

Each device on the XpressNet has to have its own address, referred to as an XpressNet address. This allows the command station to distinguish these devices from each other. Up to 31 XpressNet devices can be connected to the LZV100.

To assign an XpressNet address to a specific device please refer to the operating manuals for these devices.

The LH100 and LH90 handhelds operate as additional devices on the XpressNet and are what is referred to as a walk around device. This means that they may be unplugged and plugged in again as often as desired during operation. To achieve a high level of mobility through these devices, you can attach as many XpressNet connectors to your model railway layout as desired, so that you can always plug in your input device where you need it at the time. You will find information on this in the section "XpressNet Wiring" (⇒p. 27).

8.2 More power through more power stations

As is the case with conventional systems, a sufficient power supply is required for reliable functioning of your *Digital plus by Lenz*[®] system. Providing sufficient power is a prerequisite for the proper function of a digital layout. The number of transformer/Power Station combinations needed for the layout depends on the power needs of your layout.

Locomotives, interior lights in rolling stock, turnouts, signals etc. all get their power, along with their commands, from the Power Station. If all the devices you have connected to an LZV100 together continuously require more than 5 amps, the thermal safety circuit within the LZV100 will activate. This will result in an overload situation and the LZV100 will shut down for a brief period to cool down.

The current required by your layout is the sum of the following:

- Operating locomotives: each operating locomotive can consume between 0.2 Amps and 2 Amps depending on scale and load. For a good estimate per locomotive, use 0.3 amps for N-scale, 0.5 Amp for H0 scale and 2 Amps for O and Large Scales. This will normally provide you with plenty of reserve capacity.
- Stopped locomotives: without lights 1.5mA, with lights approximately 50mA per light bulb
- Rolling stock with lights: per light bulb approximately 50mA

The sum of all the current loads for extended periods should not exceed 5 amps for your LZV100.

If the output of your LZV100 is not powerful enough to supply the complete layout, then divide the layout into several power districts. Additional LV101 power stations then will supply those areas with approximately 4 amps each (one LV per power district). The number of power stations you need depends on the total power requirement of your model railroad.

8.2.1 **Connecting additional LV101s**

The additional LV101s receive their control signals from the terminals **C** and **D** of the first LZV100. Each LV101 should be connected to its own transformer. It is absolutely necessary that the electrical circuits of all power stations connected to each other have the same polarity. This means that terminal **J** of the LZV100 and terminal **J** of the following LV101s must be connected to the same side of the track. Otherwise there will be short-circuits when the sectioning gaps between power stations are crossed.

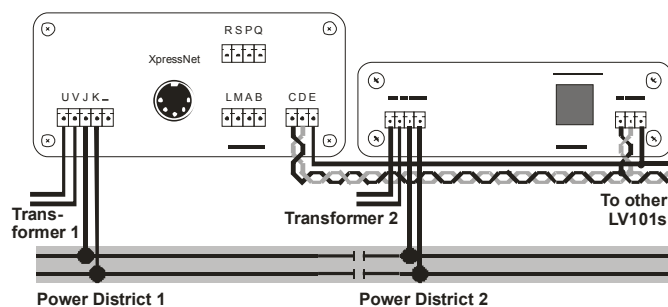

Figure 7: Connecting additional power stations

Connect terminals **C, D** (and optionally **E**) of the LZV100 with terminals **C, D** and **E** of each LV101. Power each LV101 with its own transformer.

Isolate both rails of the track at the junction of the single supply areas and make sure the polarity is the same.

If you are operating locomotives with offset pickups (common in HO scale brass steam locomotives), the you will need a common between the power stations. See "Layout Wiring considerations" later on in this manual. " (⇒p. 28).

8.3 Adding a Layout Feedback Bus

The LZV100 provides the capability for utilizing a layout feedback bus. This bus is used to interconnect sensors on the layout and is used for block occupancy, signaling, and other forms layout automation. A computer connected through an LI100F is normally used to gain full advantage of this capability.

8.4 Using RailCom

RailCom is an advanced form of communication between decoders and your control system. This will allow exciting new capabilities in the future. There are no special wiring requirements to utilize RailCom with your LZV100 as the necessary components are built into the system.

9 Installing XpressNet

The connecting wires between the LZV100 Command Station and the Hand Held Controller LH90, LH100, (or the LI100F Interface), are referred to as the **XpressNet**. The Command Station and connected devices use this computer network to exchange information.

XpressNet is an open protocol and uses the industry standard RS-485 for communication. Any certified **XpressNet** device can be used with your LZV100.

A maximum of 31 devices are allowed on **XpressNet**. Each of the connected units has its own address, so that data exchange is problem-free. Directions for how to change the address of Hand Held Controller LH100/LH90 or another input device on **XpressNet** are found in their corresponding manuals.

An **XpressNet** device can be connected to the Command Station via either a 5-pin DIN connector or through terminals **L**, **M**, **A** and **B**. You can extend your **XpressNet**, for the purpose of connecting additional Hand Held Controllers or to provide additional access points to plug these device into, by using LA150 or LA152 adaptor boards or by soldering the 4 wires to the DIN-sockets yourself. Connect your **XpressNet** to the LZV100 Command Station through terminals **L**, **M**, **A** and **B**. Via the wires at terminals **A** and **B**, the units exchange data with the Command Station. Via the wires at terminals **L** (plus) and **M** (minus) the units are supplied with power.

9.1 Using 5 pin Din Plugs

The most reliable long-term installation is to use 5 pin Din plugs. These can be obtained from most electronic parts stores or through your Lenz dealer in groups of five as part XP-5.

The assignment of the five-pin DIN-socket is shown in the following figure:

Figure 8

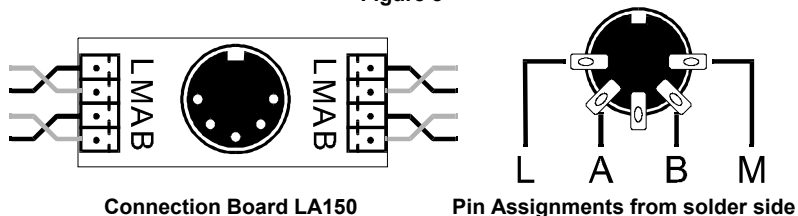

☞ Make sure that you do not mix up the cables of the terminals **L** and **M**. This could result in a short in the connected input devices.

If you are upgrading from a Set-02 you may replace the coil cord on the LH200 you used as the command station with a coil cord that has a 5-pin din connector. The DIGITAL plus part number for the cord is LY006.

9.2 Using Modular Plugs

You may use Module plugs instead of DIN plugs for wiring your XpressNet or any combination of Din and Module plugs.

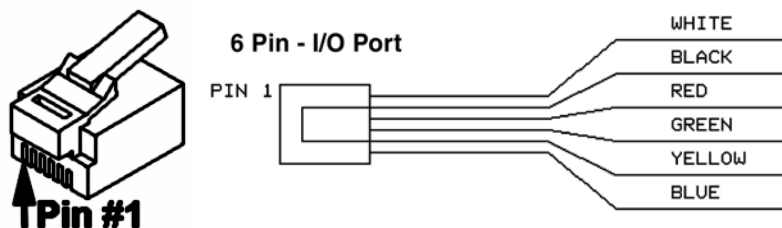

Figure 9: Module Plug Wiring

Pin #	Port A	Port B	Description
Pin 1	White	N/C	Optionally "C"
Pin 2	Black	Black	Ground "M"
Pin 3	Red	Red	- RS-485 "B"
Pin 4	Green	Green	+ RS-485 "A"
Pin 5	Yellow	Yellow	+12 volts "L"
Pin 6	Blue	N/C	Optionally : "D"

If you use module plugs you can use either 4 or 6 wire plugs.

☞ If you are upgrading from Set-02 you must remove the module plug connection to your LV100 or LV200 and instead connect your LH200 to the LZV100's XpressNet.

9.3 Using the LA152

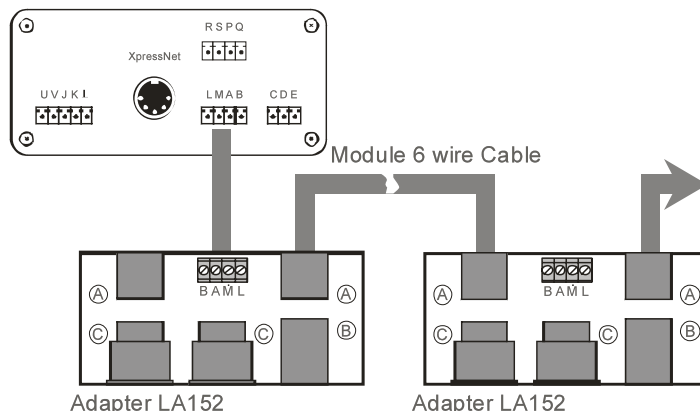

Figure 10: Connecting the LA152

To use the LA152 with an LZV100 simply connect the LMAB outputs on the rear of the LZV100 to the corresponding LMAB connection on the rear of the first LA152. Additional LA152 adapters can then be connected using either four wire RJ14 or 6 wire RJ12 cables.

9.3.1 Using Multiple LA152s

You can install any combination of LA152 and or DIN sockets around your layout that you like.

When interconnecting LA152s you can use either RJ11 4 wire cable or RJ12 6 wire cable to connect Port A of one LA152 to Port A of another LA152.

Figure 11: Module cable wiring

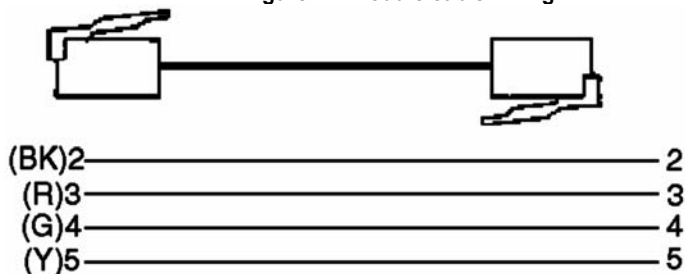

☞ Care must be taken to use reverse style modular phone cables (see above figure) to interconnect LA152s.

9.4 XpressNet Wiring

The **XpressNet** wiring must be installed so that the line starts at the Command Station and ends somewhere on your layout. (Daisy chained from Command Station via intermediate input locations to the last input location.) Between the start and end you may insert connecting panels or 5-pin DIN connectors anywhere.

You may install your XpressNet in any configuration so long as there are no loops. To install branches use a standard RJ14 or RJ12 splitter or Tee (available through your dealer or wherever phone products are sold).

For exceptionally long XpressNet installations, (more than 300ft), you should use wiring with at diameter of at least 20 gauge to ensure that sufficient power is available to power your handhelds.

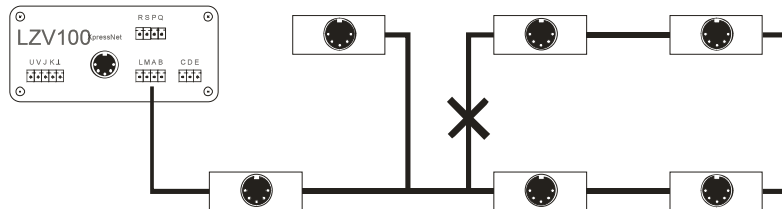

Figure 12: When wiring the X-BUS, wires must not be allowed to loop

The ends of the XpressNet Network lines **A** and **B** should be connected to the resistor, which is enclosed with the LZV100. The resistor has a value of 120 Ohm.

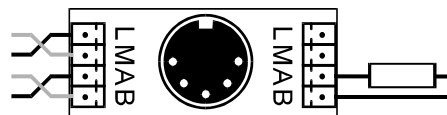

Figure 13: Terminating the XpressNET with a resistor

Which wire is best for use with XpressNET?

The minimum gauge of the wire in the XpressNet should be 24 gauge. In practice so-called "bell wire" has proved efficient. This can be acquired cheaply. It is sufficiently twisted and available in various colors. If you are using LA152 adaptors then common 6 wire phone cables can also be used.

How long may an XpressNET network be?

For reasons of physics the maximum length of the **XpressNet** depends on the kind and size of the wires used for the **XpressNet**. With normal telephone wire the length should not exceed 300 ft. If

you install a twin-core, twisted cable for the signal lines of the **XpressNet** you can increase the length to up to 3000 ft. without problems.

Installing additional XpressNet power

If your XpressNet is very long and you are using phone cables or other small gauge wire to interconnect you may find that at very distant points there is insufficient power to operate your XpressNet devices. If you encounter this problem you can install an auxiliary 12 volt DC power supply to the **L** and **M** lines. Care must be taken not to cross the wires across multiple supplies.

10 Layout Wiring considerations

There are many different wiring approaches used within model railroads. The basic difference between these wiring styles is in how the common is wired. In order to simplify the conversion to DCC, the LZV100 has been designed to support all the popular wiring approaches.

☞ **Caution:** If you decide to install a common, it is important that you only have a single common. Multiple commons (such as common rail and common transformer) should be avoided.

10.1 What is a Common?

In some scales there exist locomotives that have pickups that are offset from each other. For example many steam locomotives have power pickup from one rail in the locomotive and the other rail in the tender. When such a locomotive bridges the gap between isolated power stations, the locomotive will stall because the circuit is not complete. The solution to this problem is to provide a common wire between all the power stations. All DCC command control systems need to have such a common provided, if offset pickup locomotives are to be operated.

Lenz has chosen to leave the option of the location of the common up to the individual operator. The LZV100 is completely opto-isolated. There are no built in hidden commons. This allows you to select which common approach works best for you.

☞ For safety reasons the common should never be connected to earth ground. Such a connection is specifically prohibited by most electrical safety codes.

10.2 Common Rail Wiring

In common rail wiring one rail has the same polarity around the entire layout. If you are using such an approach it is best to have a single common point where all the commons are tied together. For best results and to prevent any possibility of double voltages connect the **J** wires on all connected power stations together and then connect this **J** common to the rail common in a single location.

10.3 Two rail wiring (Direct Home Wiring)

In two rail wiring, both rails are gapped between power districts. Because there is no rail common, a power station common can be used. The LZV100 has the terminal marked '⊥' that can be used for this purpose.

10.4 Common transformer

In common transformer wiring a single larger transformer is used to power the command station and all the power stations. If using common transformer wiring connect all the power station **U** or **V** wires together and then connect the transformer to this common wire at a single point. If using a common power supply it must be sized to meet the needs of all the connected components.

10.5 Mixing Digital and Analog Operations

Conventional and digital track sections must be consistently separated from each other by using isolating tracks or isolating rail connectors between the digital and conventional (DC=) track sections (double gapping).

At the gap dividing digital from analog operation, you must take steps to prevent interference between the 2 systems when a locomotive crosses the gap. One approach is to use a Digital Circuit Breaker such as the LT100. If a locomotive bridges the insulated gap, the module immediately interrupts the analog power supply.

Warning:

- ☞ Mixed digital/analog operations using both rails and catenary (overhead wire) is not allowed. In this mode of operation, if the locomotive is on the track in the wrong direction (for instance after going through a loop), the built-in locomotive decoder could be destroyed by excessive voltage! We suggest you operate with current pickup from the rails (wheel pickups), since that contact is more reliable (and thereby the transmission of the digital signals to the locomotive decoder) than with catenary.

10.6 Connecting a reverse loop

Lenz GmbH produces an automatic reversing module (LK100) that can be used to easily wire complex automatic reversing sections. While these units are invaluable in some cases they are not absolutely needed for DCC operations. Following is an example on how a very simple reversing section can be built.

10.6.1 Example:

Using isolated track contacts and a twin-coil relay; the polarity inside a reverse loop can be controlled to ensure that there is no short when crossing the gaps. Figure 14 illustrates an example of how this can be performed.

When passing track contact **b1**, the polarity of the loop is set to allow the train to cross the gap without a short. As the reverse loop is traversed, track contact **b2** will switch the polarity in the loop, and the adjoining gap can be crossed safely. This works because in digital operations the direction of travel is determined by the decoder and not by track polarity.

Traveling the reverse loop counter-clockwise is done in a similar manner, now contacts **a1** and **a2** ensure that proper polarity is set.

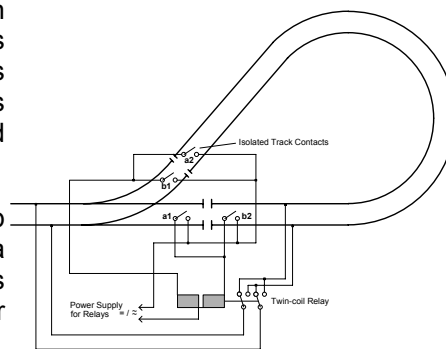

Figure 14: Wiring of Reverse Loops

10.6.2 Notes:

The distance between track contacts **a2** and **b2** must be longer

than the longest train that travels the reverse loop.

If the reverse loop is only traversed in one direction, then either contacts **a1** and **a2** or contacts **b1** and **b2** are not needed.

The track contacts used in this example can actually be auxiliary contacts set by the switch machine for the switch.

If you wish to traverse the reverse loop with a locomotive without a decoder (analog locomotive), then you must use the following sequence since the direction of travel for locomotives without a decoder is dependent on track polarity.

- move the entire train into the reverse loop (the train must be between contacts **a2** and **b2**).
- stop the train and change direction with your handheld (LH100).
- now manually change the polarity in the reverse loop (for example by using push buttons connected in parallel with track contacts **a2** and **b2**) or by throwing the turnout.
- you can now move the train through the reverse loop.

11 Connecting the LZV100 to Other Manufacturer's Power Stations (Boosters)

The LZV100 has been designed to be used with a broad range of NMRA DCC power stations.

Following are diagrams to assist you in connecting the LZV100.

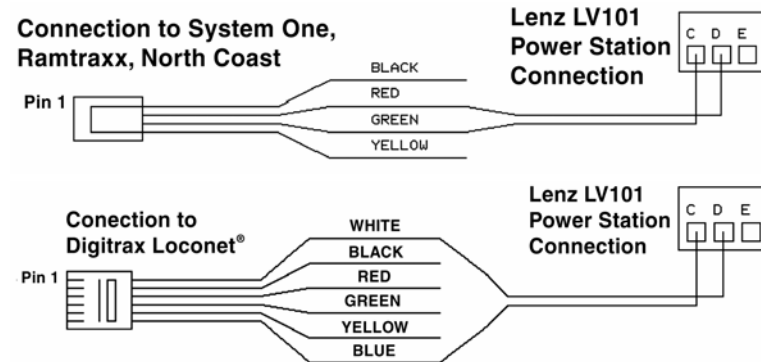

Figure 15: Connecting to other power stations

If your connections require a common ground between units the 'L' connection can be used. (⇒ p. 29)

12 Troubleshooting the LZV100

The LED on the front of the LZV100 is used to signal one of several fault conditions.

LZV100 LED	Cause	Solution
LZV100 is not operational (LED does not light)	Power supply is interrupted, power plug of transformer is not in outlet or "U", "V" wires are not connected to the transformer.	Ensure that the transformer is on, has not overloaded or shut off, check wiring from transformer to LZV100.
LED continuously on	Normal operating condition.	All is ok.
LED continuously on, but locomotives do not run	The connection from the LZV100 to the track is broken (terminals J and K).	Test and correct connections.
LED flashes slowly	The signal is not present on the C/D control bus lines	There may be a short or overload on the layout. Once the short is corrected press the emergency stop key on your handheld to restart the system. If no short is found and this happens repeatedly then you need to divide the layout into several power districts and power each district with additional power stations/transformers.
	Over-current detected (E line is active)	
	The input voltage is too low most often because the load exceeded the capability of the transformer.	A higher amperage transformer is needed to drive the desired load.
	System is in service mode	Finish programming the decoders. When service mode is exited the system will resume normal operation.

LZV100 LED	Cause	Solution
LED flashes fast	Temperature rise in the amplifier	There may be a short or overload on the layout. If no short is found and this happens repeatedly then you need to divide the layout into several power districts and power each district with additional power stations/transformers.
	Over-current detected (E line is not active)	
	Transformer is attached to J/K instead of U/V	Correct the wiring
LED shows double flashing	The power station is being programmed using ops mode programming. The next programmed value to CV7 (if valid) is used for the new setting.	Finish resetting parameters and normal operations will resume.

13 Radio And Television Interference

This equipment has been tested and found to comply with the limits for a Class B digital device, pursuant to Part 15 of the FCC rules. These limits are designed to provide reasonable protection against harmful interference in a residential installation. This equipment generates, uses and can radiate radio interference energy and, if not installed and used in accordance with the instructions, may cause harmful interference to radio communications. However, there is no guarantee that interference will not occur in a particular installation. If this equipment does cause harmful interference to radio or television reception, which can be determined by turning the equipment off and on, the user is encouraged to try to correct the interference by one or more of the following measures:

- Reorient or relocate the receiving antenna.
- Increase the separation between the equipment and the receiver.
- Connect the equipment into an outlet or on a circuit different from that to which the receiver is connected.
- Consult the dealer or an experienced radio/TV technician for help.

You may also find helpful the following booklet, prepared by the FCC: "How to Identify and Resolve Radio-TV Interference Problems." This booklet is available from the U.S. Government Printing Office, Washington D. C. 20402.

Changes and modifications not expressly approved by the manufacturer or registrant of this equipment can void your authority to operate this equipment under Federal Communications Commissions rules.

14 North American Warranty

Lenz GmbH does everything it can do to ensure that its products are free from defects and will operate for the life of your model railroad equipment. From time to time even the best-engineered products fail either due to a faulty part or from accidental mistakes in installation. To protect your investment in Digital Plus products, Lenz GmbH offers a very aggressive 10 year Limited Warranty.

This warranty is not valid if the user has altered, intentionally misused the Digital Plus product, or removed the product's protection, for example the heat shrink from decoders and other devices. In this case a service charge will be applied for all repairs or replacements. Should the user desire to alter a Digital Plus Product, they should contact Lenz GmbH for prior authorization.

Year One: A full repair or replacement will be provided to the original purchaser for any item that has failed due to manufacturer defects or failures caused by accidental user installation problems. Should the item no longer be produced and the item is not repairable, a similar item will be substituted at the manufacturers discretion. The user must pay for shipping to an authorized Lenz GmbH warranty center.

Year 2 and 3: A full replacement for any item will be provided that has failed due to manufacturer defects. A minimal service charge for shipping and handling costs will be imposed. Should the item no longer be produced and the item is not repairable, a similar item will be substituted at the manufacturer's discretion.

Year 4-10: A service charge to include repair, shipping and handling will be placed on each item that has failed due to manufacturer defects and/or accidental user installation problems. Should the item no longer be produced and the item is not repairable, a similar item will be substituted at the manufacturers discretion.

A return authorization number is necessary for warranty service. Please contact a Lenz Service Center to receive this number and give the required information.

Hüttenbergstrasse 29
35398 Giessen
Germany

Hotline: 06403 900 133
Fax: 06403 900 155
info@digital-plus.de



Lenz Agency of North America
PO Box 143
Chelmsford, MA 01824 USA

Phone: 978 250 1494
Fax: 978 455 LENZ
support@lenz.com

Warning: This product contains chemicals known to the State of California to cause cancer, birth defects or other reproductive harm.

FC This equipment complies with Part 15 of FCC Rules. Operation is subject to the following two conditions: (1) this device may not cause harmful interference, and (2) this device must accept any interference received, including interference that may cause undesired operation.

CE Please save this manual for future reference!

© 2002 Lenz GmbH, All Rights Reserved